

# Michelangelo

- Range of barriers for very intensive use, able to manage clear drive throughs up to 8 m. The wide range of accessories, the integrated flashing light and the arrangement for fitting photocells make them ideal in any context
- Control unit with programming display and incorporated two-channel radio receiver mounted on top of the machine for easier and convenient access
- Electronic adjustment limit switch system that speeds up installation and ensures maximum precision of movement
- Emergency battery power system, installable on the machine.

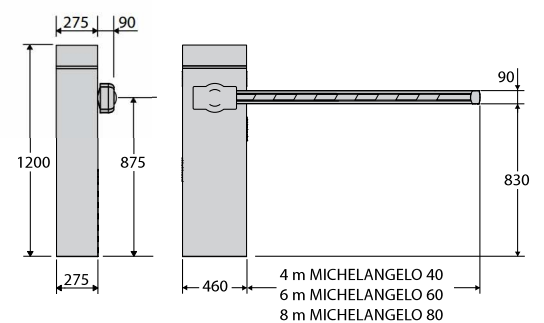
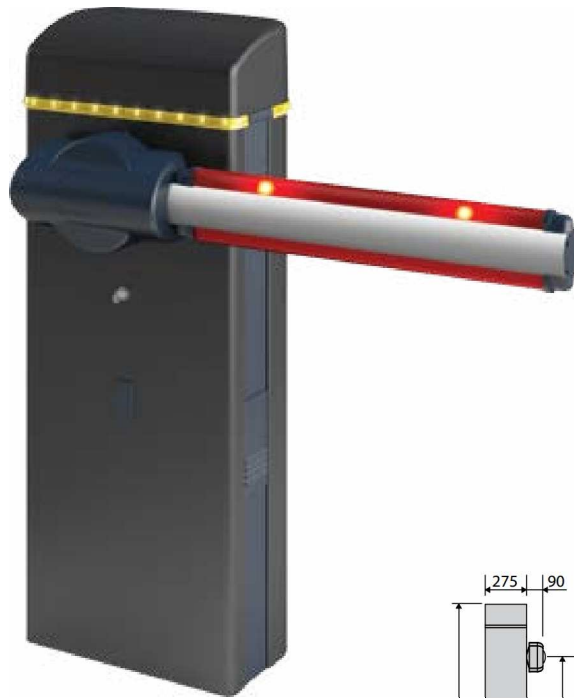

## TECHNICAL CHARACTERISTICS

	MICHELANGELO 40	MICHELANGELO 60	MICHELANGELO 80
Useful passage	4m	6m	8m
Control unit	Libra C MV		
Motor power supply	24V		
Opening or closing time	4sec.	6sec.	8sec.
Type of limit switch	electronic		
Slowdown	adjustable		
Lock	mechanical		
Release	personal release key		
Frequency of use	continuous use		
Ambient conditions	from - 20 (-40 with thermo activation)°C to 50°C		
Protection rating	ip24		